

CATÁLOGO



SR GRUPO EMPRESARIAL

Importação, Exportação e Representação Comercial

www.srgrupoempresarial.com.br

(21) 3190-3884



(21) 96441-0003

Avenida das Américas, 13733, sl 205,
Recreio dos Bandeirantes, Rio de Janeiro, Brasil

SR GRUPO EMPRESARIAL

Com ampla expertise em logística internacional, oferecemos serviços em importação e exportação, além de consultoria e representação comercial para empresas que buscam expandir seus negócios.

Nossas parcerias com grandes indústrias brasileiras e internacionais nos permitem apresentar, em nosso portfólio, uma vasta gama de materiais, peças, insumos e equipamentos para atendimento aos mais diversos setores.



NOSSOS SERVIÇOS:

IMPORTAÇÃO

Soluções em nacionalização! Com nossa expertise e conhecimento do mercado internacional, importamos materiais, peças, insumos e equipamentos para atendimento aos mais diversos setores.

EXPORTAÇÃO

Ampliamos seus horizontes! Com nossa experiência logística e ampla rede de contatos no mercado exterior global, oferecemos as mais diversas soluções pra você que deseja exportar, para os mais diversos setores.

REPRESENTAÇÃO COMERCIAL

Seja destaque e aumente seu potencial de vendas! Pra você que deseja maior visibilidade, tanto no mercado brasileiro quanto internacional, oferecemos serviços de representação comercial, onde cuidamos de todas as etapas do processo.

VENDA DIRETA

Somado ou não aos nossos serviços de representação comercial, oferecemos nossas soluções em venda direta, conectando a vossa empresa ao seu público alvo, revendendo seus materiais, peças, insumos e equipamentos para clientes finais dos mais diversos setores.



SR GRUPO
EMPRESARIAL



CONTACT
US





SR GRUPO
EMPRESARIAL

SR IMPORTAÇÃO

Linha Marítima

Correntes, Ancoragem & Amarração

EXEMPLOS DE CORRENTES



CORRENTE DE ÂNCORA DE ELO DE PINO GRAU 3



CORRENTE DE ÂNCORA DE ELO DE PINO GRAU 2



CORRENTE DE ANCORAGEM EM AÇO INOX



CORRENTE DE ÂNCORA DE ELO SEM PINÇA DE ELO ABERTO



CORRENTE DE ANCORAGEM GALVANIZADA



CADEIA DE BOIAS



QUALIDADE GARANTIDA!

Contando com linhas e processos de produção avançados e tecnologia de ponta, nossos parceiros fabris possuem as mais diversas certificações, realizando rigorosamente a gestão da qualidade de acordo com as regras exigidas pelas mais importantes sociedades de classificação, em conformidade e consonância com as diretrizes, normas e padrões nacionais e internacionais.



EXEMPLOS DE CERTIFICAÇÕES

UM DE NOSSOS PARCEIROS FABRICANTES:

Com capacidade anual de produção de 20.000 toneladas, conta com equipamentos de tratamento, testes de tração, além de Linha fabril com execução em conformidade com as normativas ISO1704 e GB549, utilizando para produção de amarras os processos de flash automático completo avançado na soldagem e tecnologia de têmpera metálica, permitindo a personalização de diversos produtos finais.



LINHA DE PRODUÇÃO



SR GRUPO
EMPRESARIAL



INSPEÇÃO COM TECNOLOGIA AVANÇADA



PROCESSO DE PRODUÇÃO



1



2

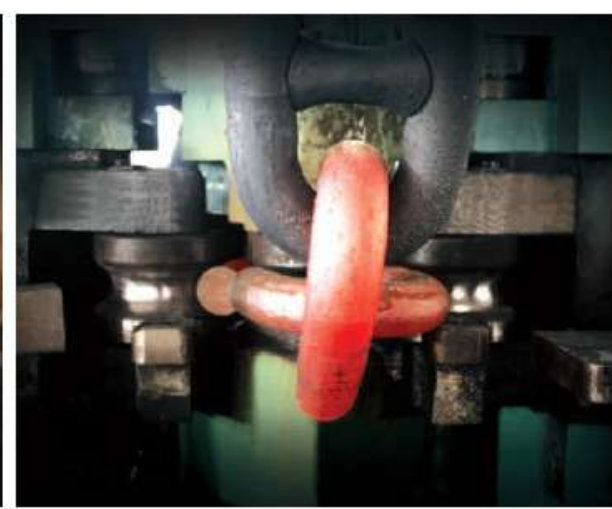

3



4



5

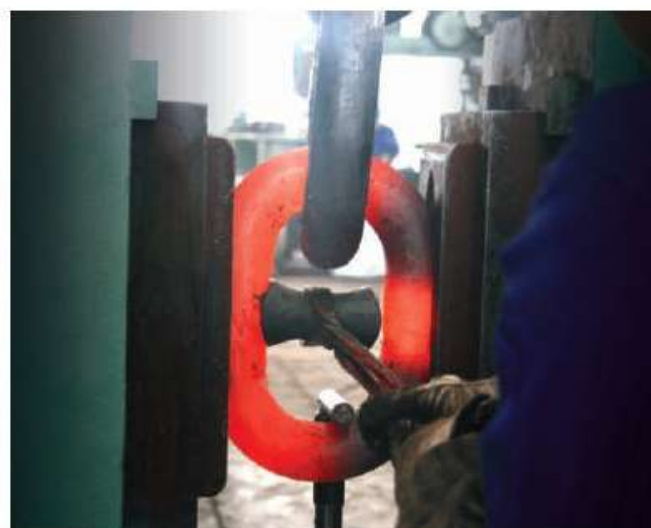

6



7



8



9

CADEIAS DE AMARRAS

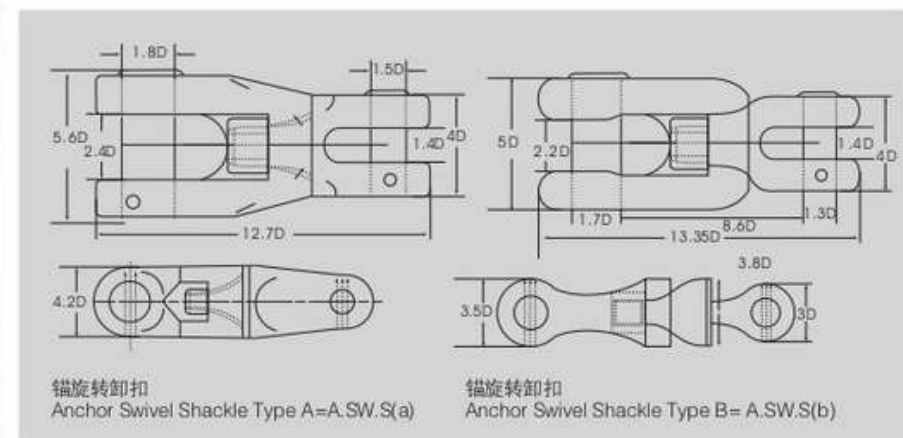
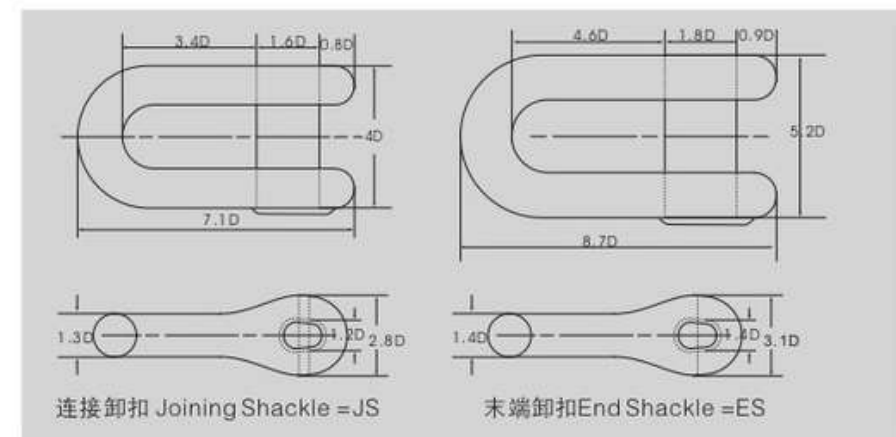
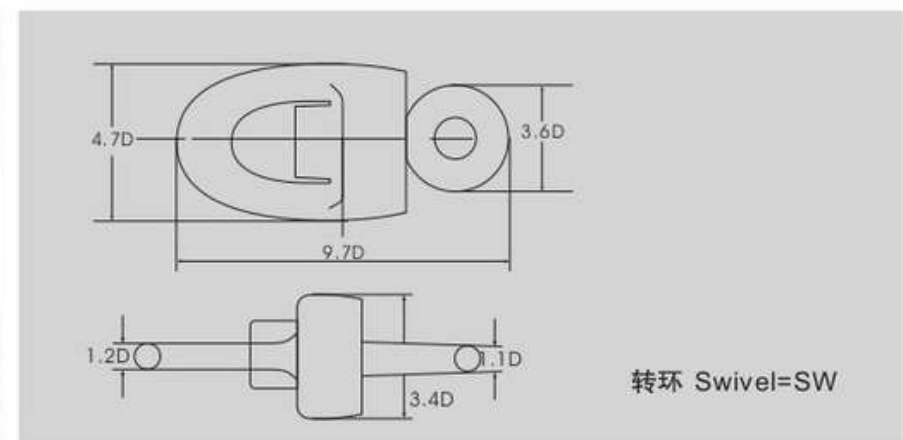
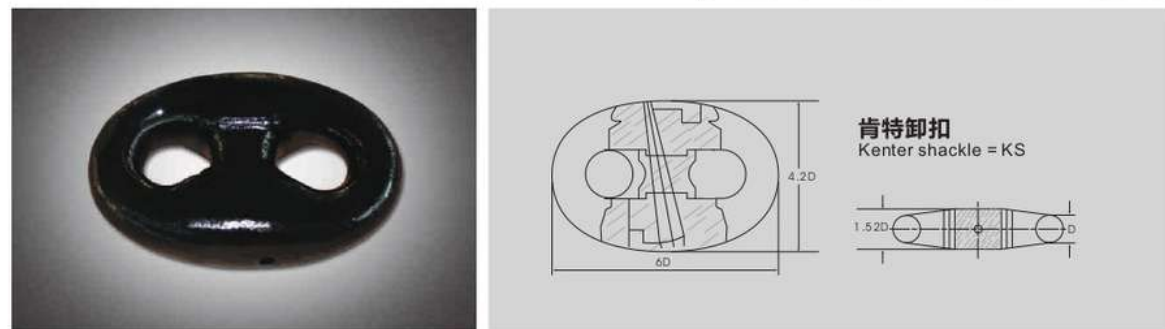
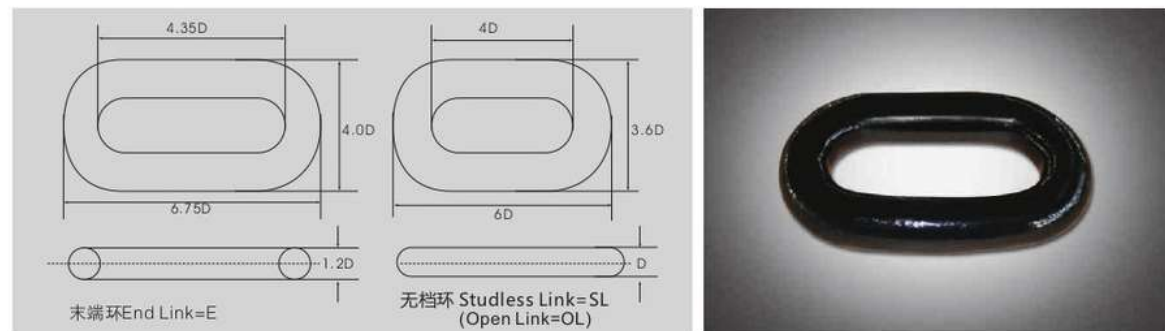
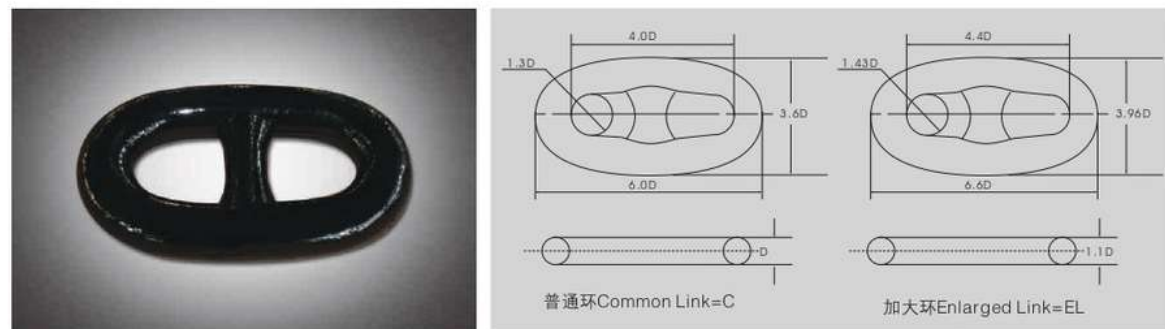

三环组 Three Links Adaptor



转环组 Swivel Forerunner



前锁卸扣 Forelock Shackle



MANILHAS PARA AMARRAS COM PINO TIPO PARAFUSO

- PRINCIPAIS PARÂMETROS TÉCNICOS:

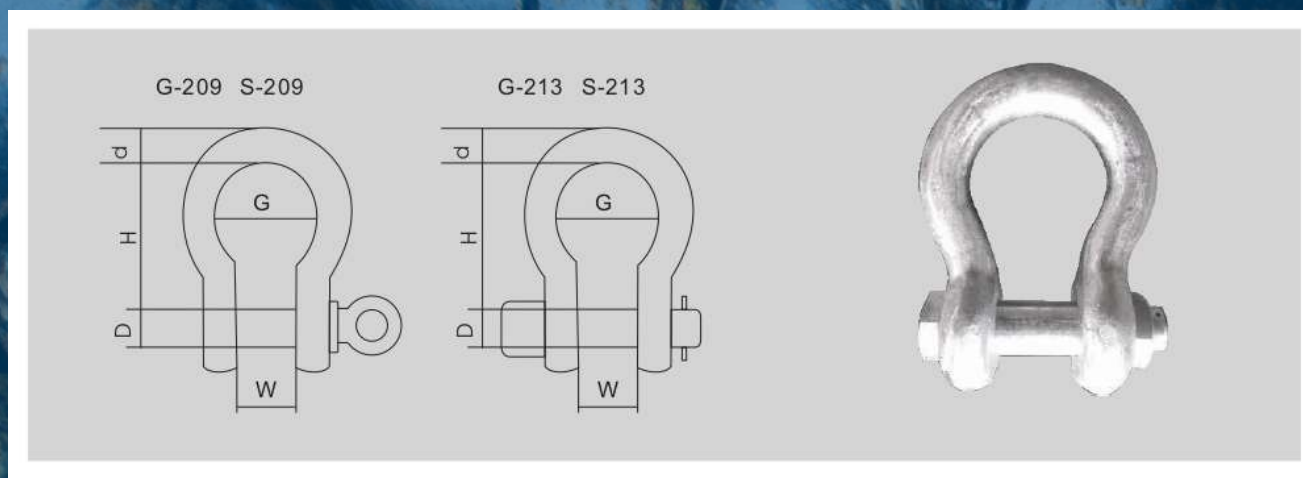

S.W.L 吨位 (Tons)	d	D	W	H	G
0.33	5	6	10	22	17
0.5	6	8	13	29	19
0.75	8	10	13	31	21
1	10	11	17	37	26
1.5	11	13	18	43	29
2	13	16	21	48	33
3.25	16	19	27	60	42
4.75	19	22	32	71	50
6.5	22	25	36	84	58
8.5	25	29	43	95	68
9.5	29	32	46	108	73
12	32	35	52	119	82
13.5	35	38	53	132	89
17	38	41	60	146	98
25	44	51	73	178	127
35	51	57	83	197	146
55	64	70	105	267	184

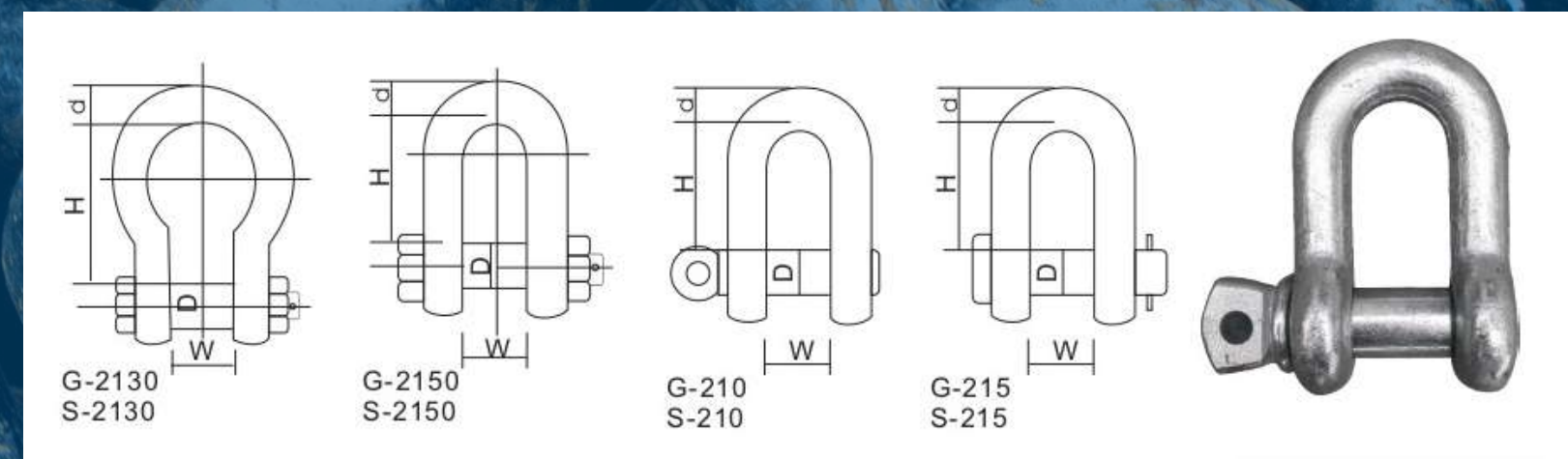

S.W.L 规格	d	2130 H	2150 H	D	W
2	13	48	41	16	20
3.25	16	60	51	19	27
4.75	19	71	60	22	32
6.5	22	84	71	25	36
8.5	25	95	81	29	43
9.5	29	108	90	32	46
12	32	119	100	35	51
13.5	35	132	111	38	57
17	38	146	122	41	60
25	44	178	146	51	73
35	51	197	171	57	83
55	64	267	203	70	105
85	76	330	216	83	127
120	88	371	-	95	133
150	102	368	-	108	140

S.W.L 规格	d	H	D	W
0.5	6	22	8	12
0.75	8	26	10	13
1	10	32	11	17
1.5	11	37	13	18
2	13	41	16	21
3.25	16	51	19	27
4.75	19	60	22	32
6.5	22	71	25	37
8.5	25	81	29	43
9.5	29	90	32	46
12	32	100	35	52
13.5	35	111	38	57
17	38	122	41	60
25	44	146	51	73
35	51	171	57	83
55	64	203	70	102



MANILHAS MARÍTIMAS

-PRINCIPAIS PARÂMETROS TÉCNICOS:

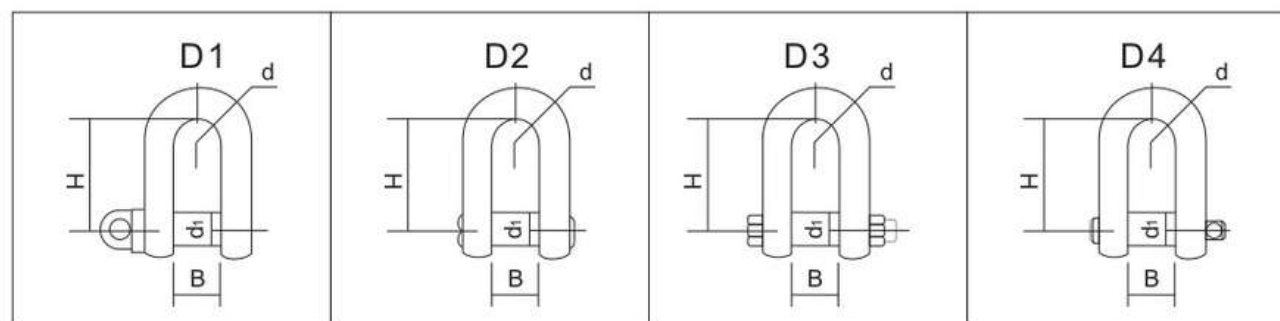

直形卸扣 STRAIGHT UNLOADING BUCKLE D1、D2、D3、D4					
许用负荷 acceptable load KN	公称尺寸 size (mm)				重量 Weight (kg)
	B	H	D1	d	
3.92	13	33.0	9	8	0.059
4.90	14	36.0	10	9	0.086
6.27	16	41.0	12	10	0.142
7.84	18	46.5	14	12	0.193
9.80	20	51.5	15	13	0.279
12.25	22	57.5	17	15	0.383
15.68	25	64.5	19	17	0.538
19.60	28	72.5	21	19	0.760
24.50	31	81.0	24	21	0.986
31.36	35	91.5	27	24	1.421
39.20	40	102.0	30	26	1.985
49.00	44	113.5	33	29	2.769
61.74	50	127.5	37	33	4.060
78.40	56	144.0	42	37	5.900
98.00	63	161.5	47	41	8.150
125.50	70	180.5	53	46	10.78
156.80	79	204.0	60	52	16.30
196.00	89	228.5	67	59	22.73
245.00	99	253.5	75	65	31.685
313.60	112	289.5	84	74	39.56
392.00	125	322.0	94	83	52.22
490.00	140	361.0	106	92	71.60
617.40	157	405.5	119	104	118.22
784.00	177	457.0	134	117	179.32

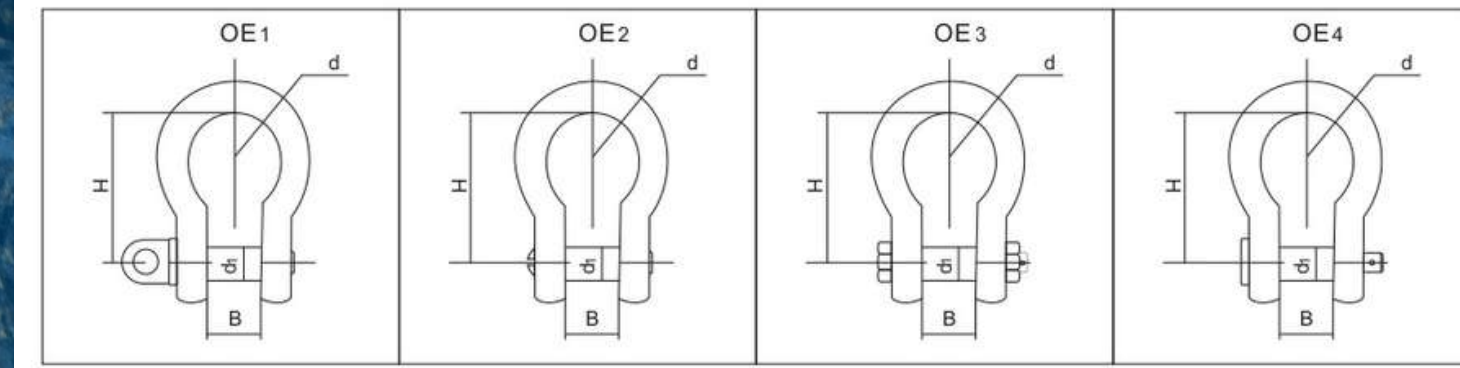

弓形卸扣 ARCHED UNLOADING BUCKLE OE ₁ OE ₂ OE ₃ OE ₄					
许用负荷 acceptable load KN	公称尺寸 size (mm)				重量 Weight (kg)
	B	H	D1	d	
3.92	18	50.5	11	10	0.150
4.90	20	56.0	12	11	0.188
6.27	23	64.5	14	13	0.287
7.84	25	70.0	15	14	0.372
9.80	28	79.5	17	16	0.491
12.25	32	88.5	19	18	0.700
15.68	36	101.0	22	20	1.034
19.60	40	112.5	25	23	1.765
24.50	45	126.5	28	25	2.215
31.36	51	141.5	31	29	2.940
39.20	57	159.5	35	32	4.240
49.00	63	177.5	39	36	6.010
61.74	71	200.0	44	40	8.470
78.40	80	224.5	49	45	11.780
98.00	90	251.5	55	50	16.750
122.50	100	281.5	62	56	21.340
156.80	113	318.0	70	64	31.690
196.00	126	355.0	78	71	44.930
254.00	142	397.5	87	79	60.620



LINHA DE CORRENTES MINERAÇÃO

PLACA/VELO TRIANGULAR

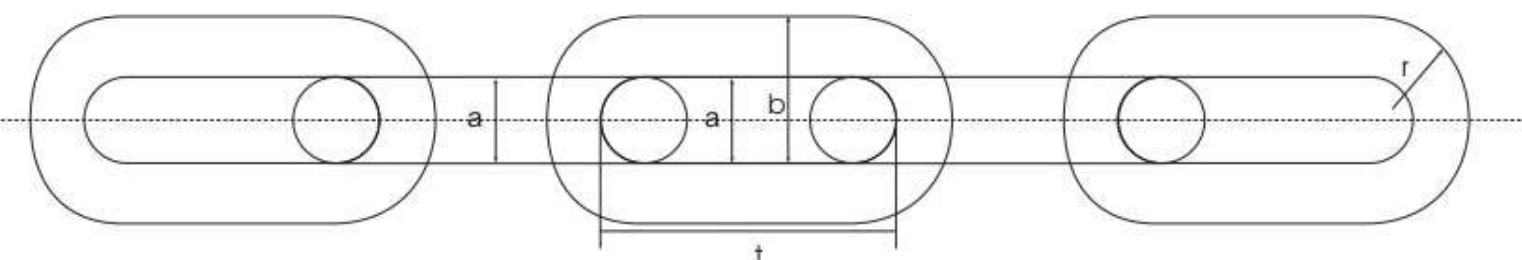

链径 d Chain Diameter (mm)	节距 t Pitch of Chain Link (mm)	宽度 Width		圆弧半径 r Curve Radius (mm)		重量 Weight (Kg/m)		
		内旁 a Inside Min.	外旁 b outside Max.					
14	±0.4	50	±0.5	17	48	22	+2.0	4.0
18	±0.5	64	±0.6	21	60	28	+2.0	6.6
22	±0.7	86	±0.9	26	74	34	+2.0	9.5
24	±0.8	86	±0.9	28	79	37	+2.0	11.6
26	±0.8	92	±0.9	30	86	40	+2.0	13.7
30	±0.9	108	±1.0	34	98	46	+2.0	18.0

圆环链规格 Round Link Chain Size (mm)	试验负荷 (KN) Proof load (KN)		最小破断负荷 (KN) Min. Breaking load (KN)	
	B级 Grade B	C级 Grade C	B级 Grade B	C级 Grade C
14×50	150	200	200	250
18×64	260	330	330	410
22×86	380	490	490	610
24×86	460	580	580	720
26×92	540	680	680	850
30×108	710	900	900	1130

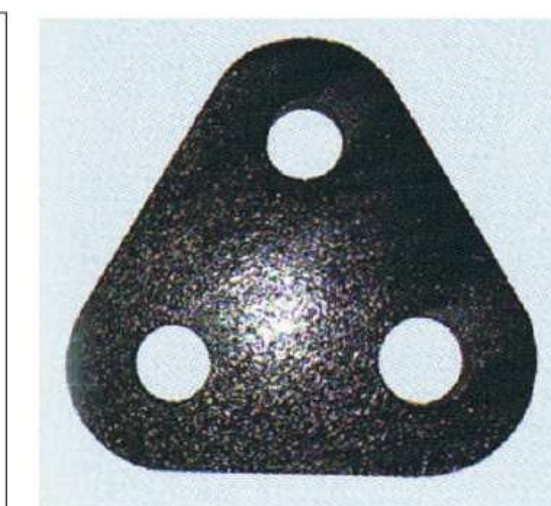
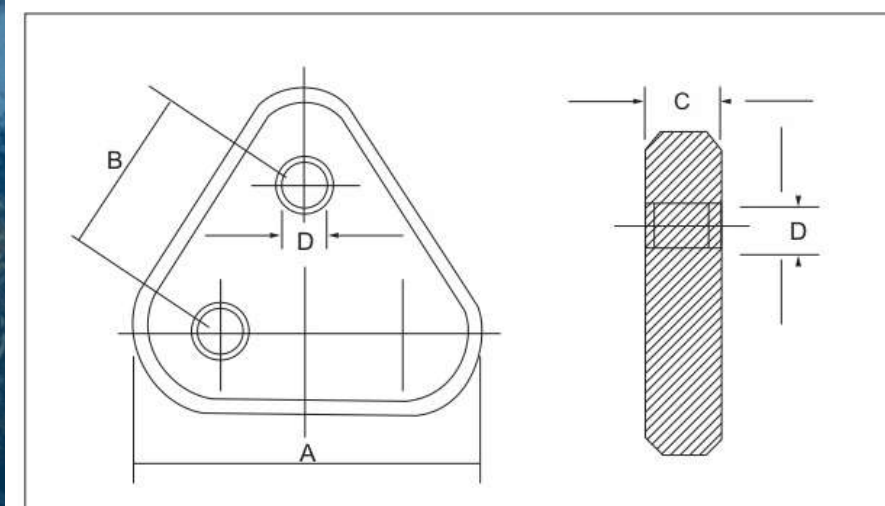

PRINCIPAIS PARÂMETROS TÉCNICOS:

Chain size in mm	A (mm)	B (mm)	C (mm)	D (mm)	Proof load Tonnes	Breaking Load Tonnes	Weight kg
38	320	168	50	76	81.2	106	13
48	360	184	60	88	127	181	25
58	430	225	80	102	190	287	50
70	506	266	90	120	270	404	81
76	550	290	90	130	313	472	96
83	600	316	100	142	356	549	127
95	685	361	120	162	508	794	199
102	736	388	120	174	594	910	230

D (mm)	D7 (mm)	B (mm)
11	17	88
12.5	18	108
14	22	112
16	24	128
17.5	25	140
19	29	152
20.5	31	164
22	34	176
24	36	192
26	39	208
28	40	224

D (mm)	D7 (mm)	B (mm)
30	45	240
32	48	256
34	50	272
36	54	288
38	56	304
40	60	320
42	63	336
44	66	352
46	69	368
48	72	384
50	75	400

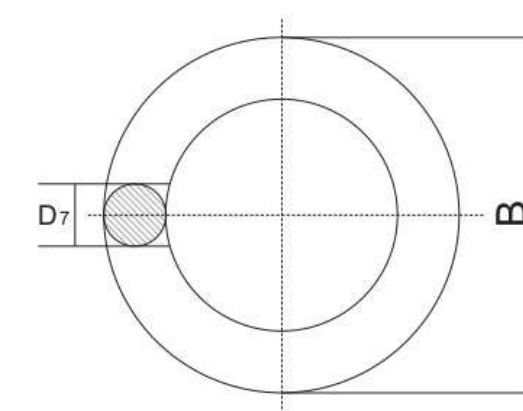

CORRENTES TIPO "BÓIA"

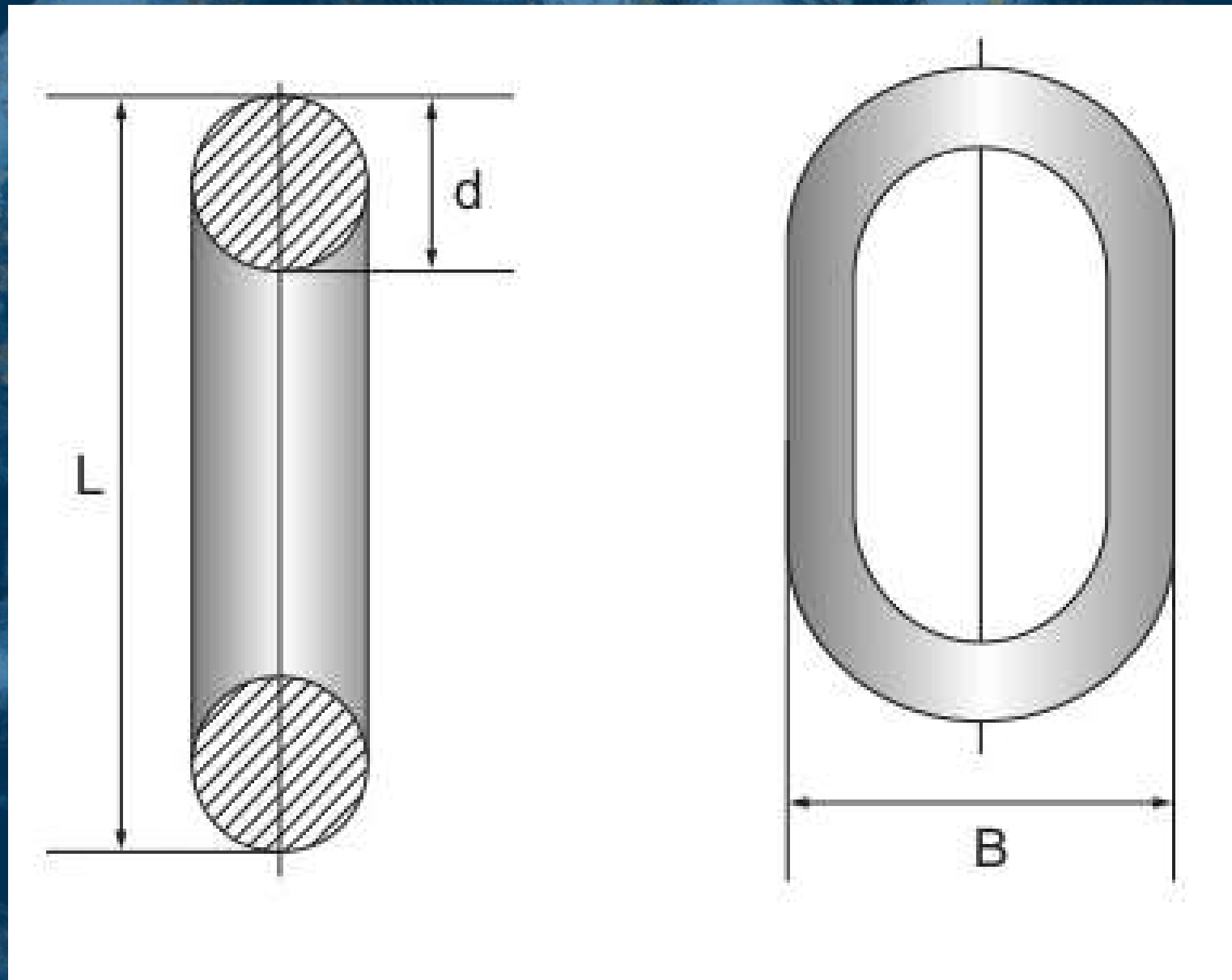

名称 Name	普通链环 Main Link	加大链环 Enlarged Link	末端链环 End Link	加粗链环 Thickening Link	转环 Swivel	末端卸扣 End Shackle	连接卸扣 D-Type Joining Shackle
序号 No	1	2	3	4	5	6	7
链环直径 Diameter 浮标规格 Duoy type							
HF0.6-D1	11	12.5	13	-	13	15	14
HF0.8-D1	12.5	14	16	-	15	17.5	16
HF1.08-D1	14	16	17.5	-	17	19.5	19
HF1.2-D1	17.5	19	20.5	-	21	24.5	23
HF1.5-D1	22	24	26	-	26	31	29
HF1.8-D1	28	30	34	40	34	39	36
HF2.4-D1	34	36	40	46	41	48	44
HF2.4-D2	38	40	46	50	46	53	49
HF3.0-D1	42	45	50	55	50	59	55
HF3.6-D1	44	48	53	62	53	62	58

名称 Name	圆令 Round Ring	马鞍链节 Bridle Chain		短链节 Short Chain		半链节 Half Chain		全链节 Main Chain	
序号 No	8	I		II		III		IV	
链环直径 Diameter 浮标规格 Duoy type		长度 Length (M)	重量 Weigth (Kg)	长度 Length (M)	重量 Weigth (Kg)	长度 Length (M)	重量 Weigth (Kg)	长度 Length (M)	重量 Weigth (Kg)
HF0.6-D1	17	2.27	3.89	4.5	6.04	13.7	17.97	27.5	35.91
HF0.8-D1	18	2.72	7.59	4.5	11.63	13.7	34.03	27.5	67.63
HF1.08-D1	22	2.76	10.37	4.5	16.24	13.7	47.64	27.5	94.73
HF1.2-D1	25	2.77	18.44	4.5	27.78	13.7	81.64	27.5	162.42
HF1.5-D1	34	2.79	31.73	4.5	47.03	13.7	136.75	27.5	269.71
HF1.8-D1	40	3.94	65.42	4.5	79.39	13.7	222.58	27.5	442.36
HF2.4-D1	50	5.26	153.65	4.5	114.15	13.7	328.86	27.5	650.91
HF2.4-D2	56	5.24	197.44	4.5	136.26	13.7	397.66	27.5	774.37
HF3.0-D1	62	6.12	228.21	4.5	180.25	13.7	542.12	27.5	1080.28
HF3.6-D1	66	6.4	310.12	4.5	207	13.7	613.50	27.5	1227.16



SR GRUPO
EMPRESARIAL

EXEMPLOS DE MONTAGEM - CORRENTES DE ANCORAGEM

MANINHAS COM UNIÃO TIPO D:

MANILHAS TIPO KENTER:

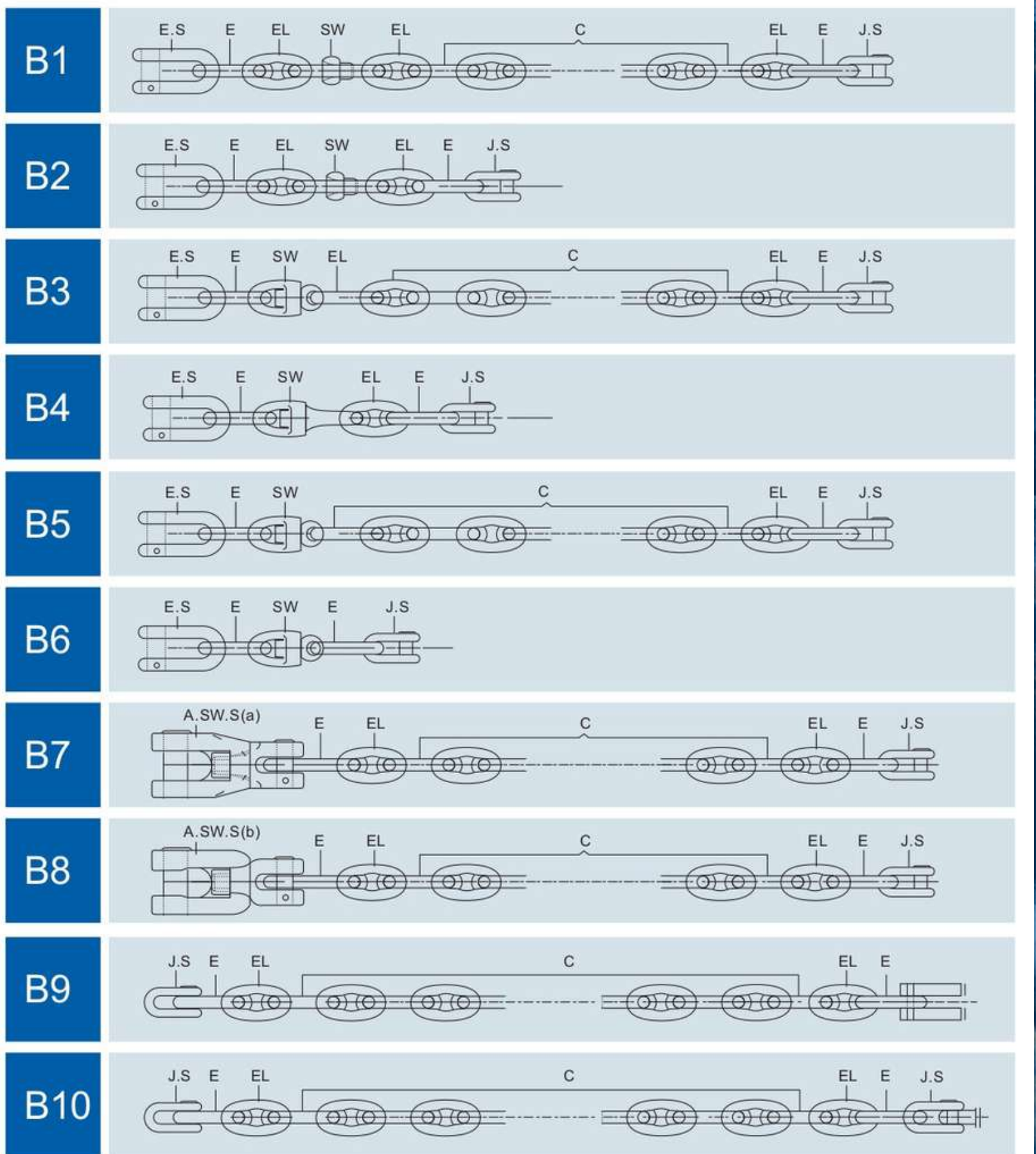
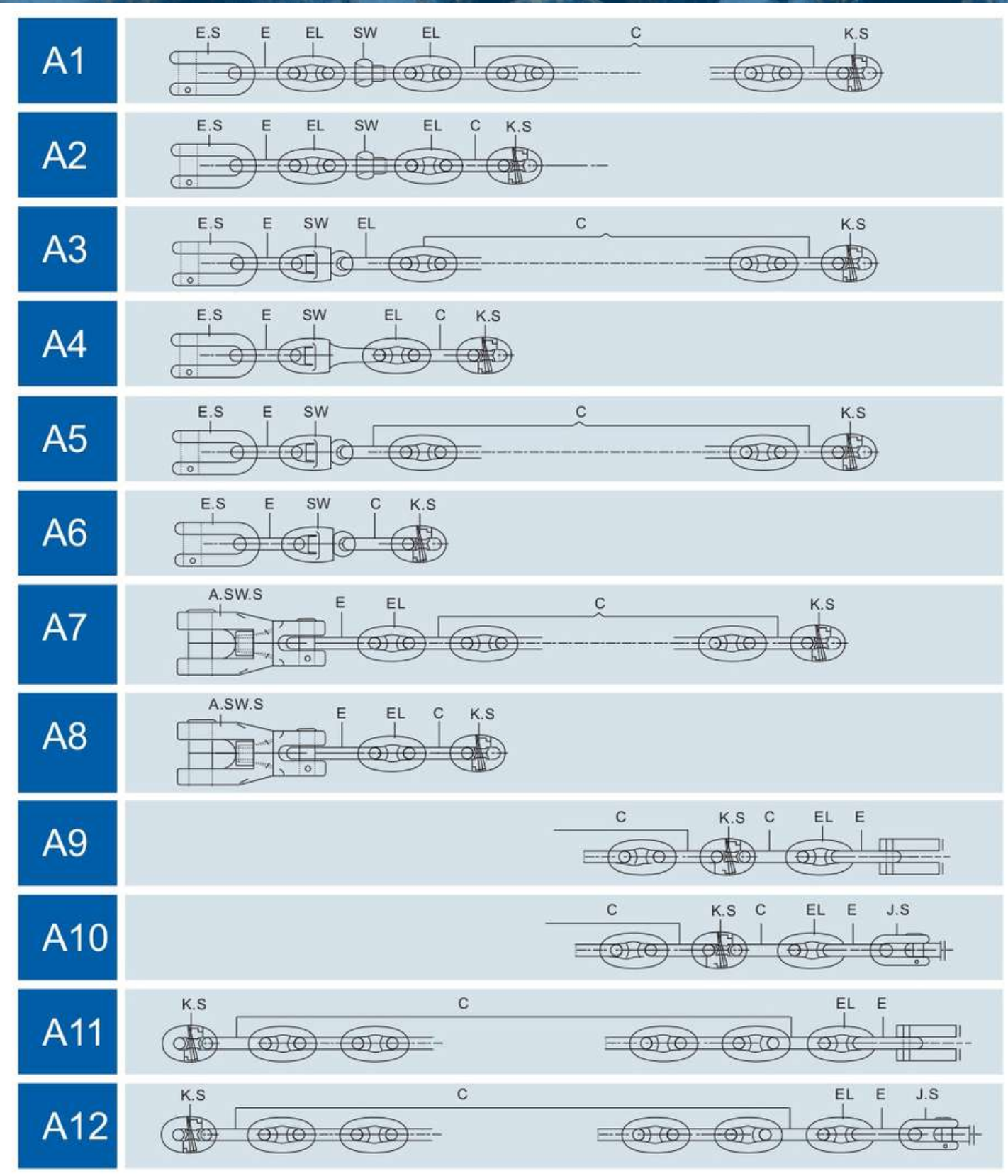

EXEMPLOS DE MONTAGEM - CORRENTES TIPO BÓIA

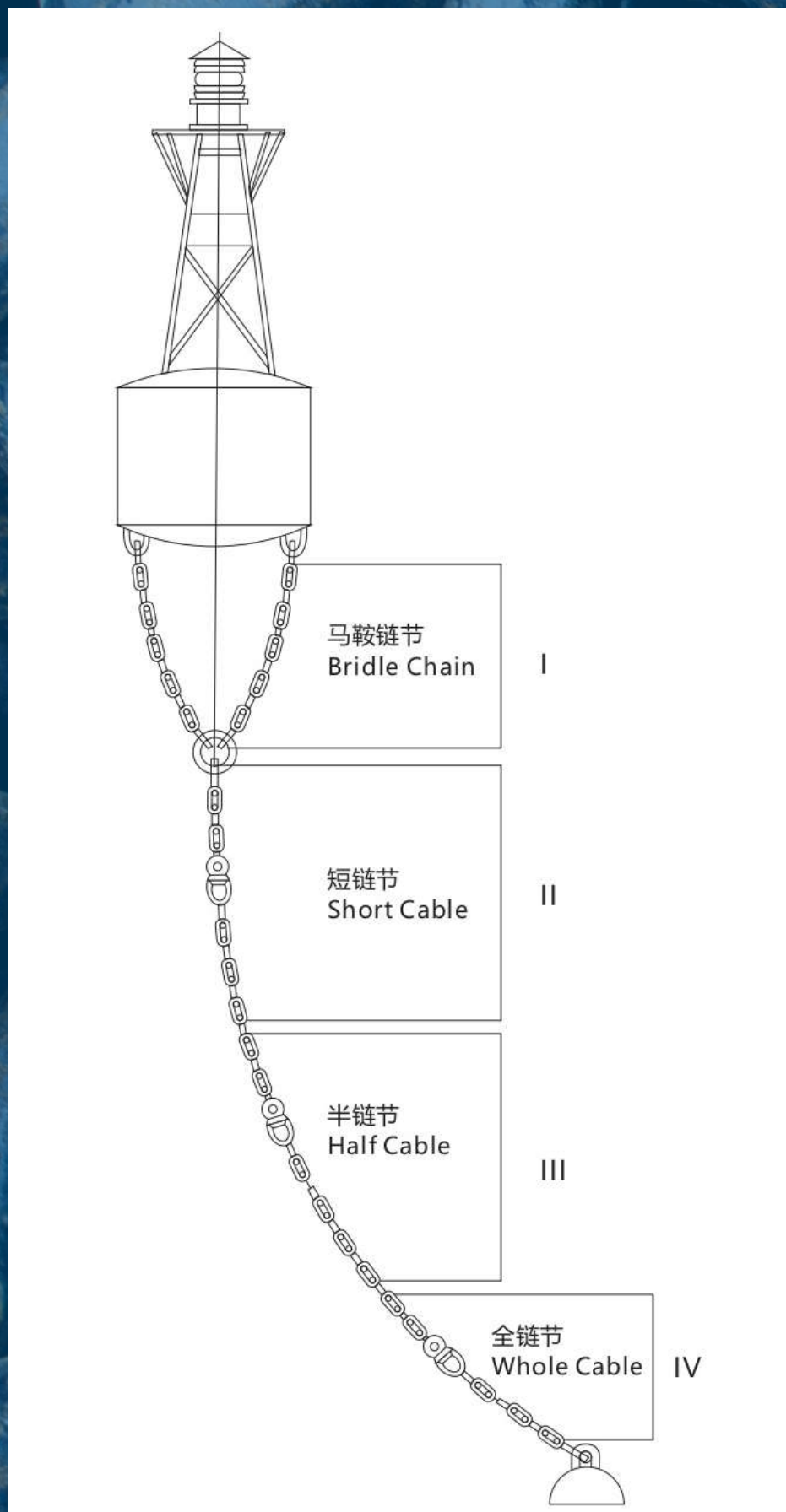

I 马鞍链节 Bridle Chain



II 短链节 Short cable

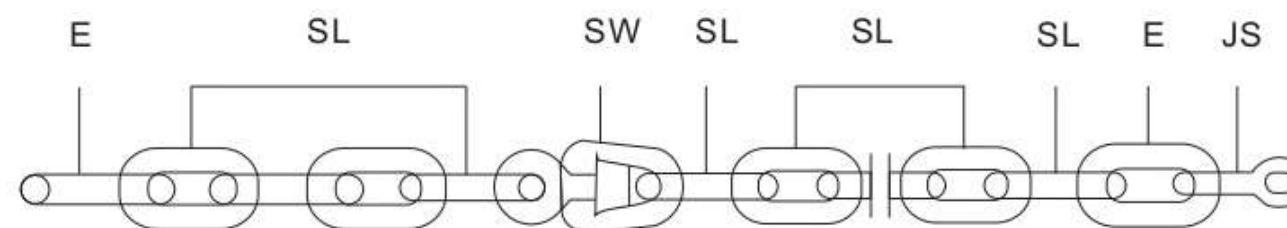

III 半链节 Half cable

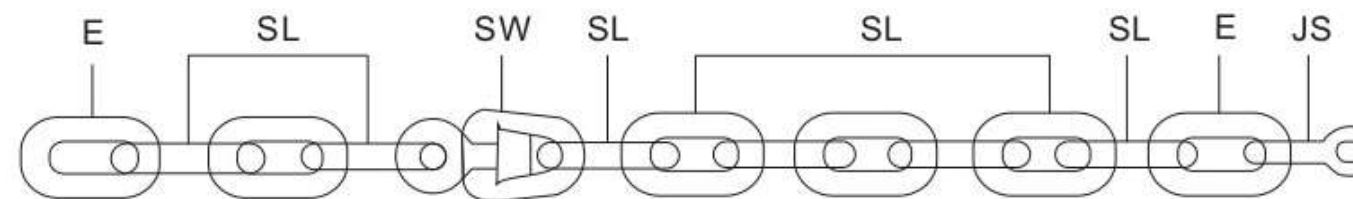

IV 全链节 Whole cable

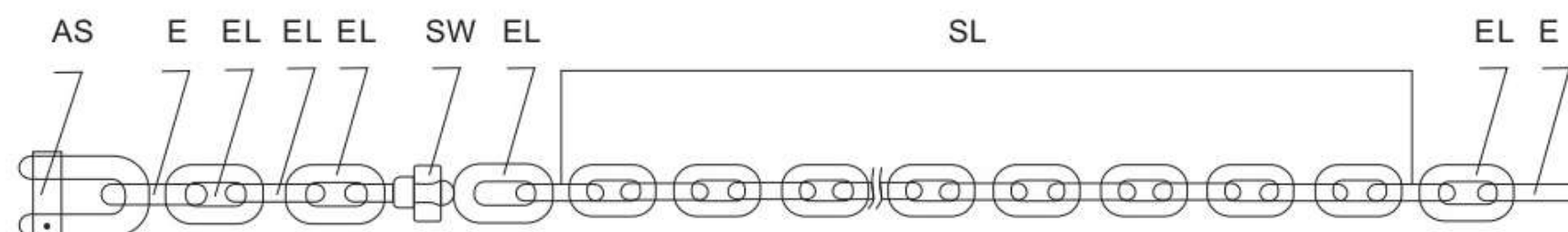

EXEMPLOS DE ÂNCORAS

GLÁSSICA (TIPO STOCKLESS)

无杆锚
Stockless Anchor

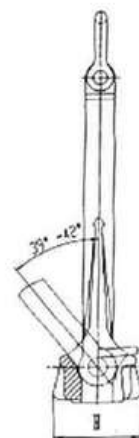
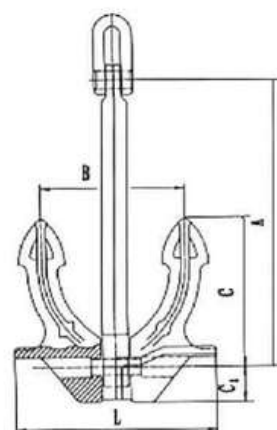

锚重 kg	A	B	C	C ₁	L	H
50	450	284	270	65	400	172
75	550	339	318	82	480	200
100	760	381	358	92	540	232
120	800	402	420	97	570	245
140	840	424	443	102	600	258
165	880	445	466	107	630	271
180	910	459	480	111	650	280
200	920	466	487	112	660	284
240	1010	510	530	122	720	310
300	1080	540	570	131	770	331
360	1150	580	610	139	820	353
420	1200	610	640	146	860	370
480	1260	640	670	153	900	387
570	1330	670	700	162	950	408
660	1400	710	740	170	1000	430
780	1480	750	780	180	1060	456
900	1550	780	820	189	1110	477
1020	1620	820	860	197	1160	500
1140	1680	850	890	204	1200	520
1290	1750	880	920	212	1250	540
1440	1820	920	960	221	1300	560
1590	1880	950	990	228	1340	580
1740	1930	980	1020	235	1380	600
1920	2000	1010	1060	243	1430	620
2100	2060	1040	1090	250	1470	640
2280	2110	1070	1120	257	1510	650
2460	2170	1100	1150	264	1550	670
2640	2230	1120	1180	270	1590	690
2850	2280	1150	1210	277	1630	700
3060	2340	1180	1240	284	1670	720
3300	2390	1210	1270	291	1710	740
3540	2450	1240	1290	298	1750	750
3780	2510	1260	1320	304	1790	770
4050	2560	1290	1350	311	1830	790

锚重 kg	A	B	C	C ₁	L	H
4320	2620	1320	1380	318	1870	800
4590	2670	1350	1410	325	1910	820
4890	2730	1380	1440	332	1950	840
5250	2800	1410	1480	340	2000	860
5610	2860	1440	1510	347	2040	880
6000	2930	1480	1540	355	2090	900
6450	3000	1510	1580	364	2140	920
6900	3070	1550	1620	372	2190	940
7350	3140	1580	1650	380	2240	960
7800	3190	1610	1680	388	2280	980
8300	3260	1650	1720	396	2330	1000
8700	3320	1670	1750	403	2370	1020
9300	3390	1710	1790	411	2420	1040
9900	3460	1740	1820	420	2470	1060
10500	3530	1780	1860	428	2520	1080
11100	3600	1820	1900	437	2570	1100
11700	3650	1840	1930	444	2610	1120
12300	3710	1870	1960	450	2650	1140
12900	3770	1900	1990	457	2690	1160
13500	3840	1940	2020	466	2740	1180
14100	3890	1960	2050	473	2780	1200
14700	3950	1990	2080	479	2820	1210
15400	4000	2020	2110	486	2860	1230
16100	4060	2050	2140	493	2900	1250
16900	4130	2080	2180	500	2950	1270
17800	4200	2120	2210	510	3000	1290
18800	4280	2160	2260	520	3060	1320
20000	4370	2200	2300	530	3120	1340
21500	4480	2260	2360	540	3200	1380
23000	4580	2310	2410	560	3270	1410
24500	4680	2360	2460	570	3340	1440
26000	4770	2410	2520	580	3410	1470
27500	4860	2450	2560	590	3470	1490
29000	4940	2490	2610	600	3530	1520



SR GRUPO EMPRESARIAL

TIPO SALÃO:

霍尔锚
Hall Anchor

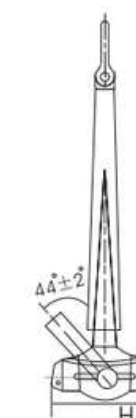
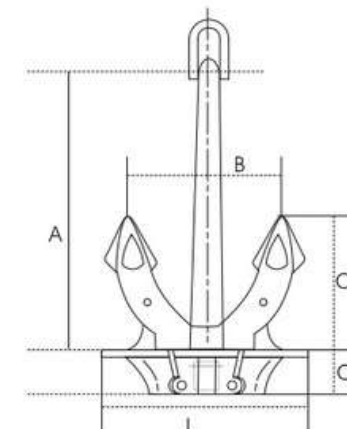

锚重 kg	A			B	C	C ₁	L	H
	A型	B型	C型					
40	557	557	430	303	303	67	430	198
60	637	637	492	347	347	76	492	227
100	760	760	590	410	410	90	582	270
125	814	814	629	443	443	97	629	290
150	866	866	665	470	470	103	670	308
180	919	919	710	500	500	110	710	327
240	1019	1019	788	552	552	121	784	361
300	1095	1095	850	595	595	130	844	388
360	1160	1160	898	630	630	138	898	412
420	1222	1222	946	660	660	145	946	434
480	1282	1282	986	690	690	152	988	454
570	1356	1356	1042	732	732	161	1042	481
660	1422	1422	1093	769	769	169	1096	506
780	1506	1506	1159	813	813	178	1160	535
900	1580	1580	1215	855	855	188	1220	560
1020	1645	1645	1268	891	891	195	1268	584
1140	1705	1705	1316	926	926	203	1319	605
1290	1778	1778	1378	965	965	211	1374	630
1440	1844	1844	1448	1001	1001	219	1430	655
1590	1906	1906	1511	1035	1035	226	1475	677
1740	1966	1966	1571	1068	1068	234	1517	698
1920	2031	2031	1602	1104	1104	241	1568	722
2100	2093	2093	1651	1136	1136	249	1614	743
2280	2150	2150	1716	1165	1165	255	1657	763
2460	2207	2207	1785	1194	1194	262	1700	784
2640	2259	2259	1843	1221	1221	268	1741	801
2850	2318	2318	1890	1253	1253	275	1787	822
3060	2374	2374	1935	1283	1283	282	1832	841
3300	2432	2432	1985	1317	1317	288	1880	862
3540	2490	2490	2032	1349	1349	295	1926	883

锚重 kg	A			B	C	C ₁	L	H
	A型	B型	C型					
3780	2547	2547	2077	1376	1376	302	1965	902
4050	2610	2610	2125	1406	1406	309	2008	924
4320	2661	2661	2171	1435	1435	316	2051	943
4590	2712	2712	2216	1465	1465	322	2093	962
4890	2769	2769	2263	1498	1498	329	2135	984
5250	2836	2836	2317	1535	1535	337	2185	1008
5610	2899	2899	2369	1569	1569	345	2234	1031
6000	2965	2965	2422	1605	1605	352	2284	1054
6450	3037	/	2482	1644	1644	361	2340	1080
6900	3100	/	2538	1681	1681	369	2393	1105
7350	3173	/	2592	1717	1717	377	2444	1129
7800	3235	/	2644	1752	1752	385	2493	1152
8300	3303	/	2699	1788	1788	393	2545	1176
8700	3355	/	2742	1816	1816	399	2585	1195
9300	3430	/	2804	1857	1857	408	2643	1222
9900	3502	/	2863	1896	1896	417	2699	1248
10500	3571	/	2920	1934	1934	425	2752	1273
11100	3638	/	2975	1970	1970	433	2803	1297
11700	3702	/	3028	2005	2005	441	2853	1320
12300	3764	/	3079	2039	2039	448	2901	1342
12900	3824	/	3128	2072	2072	455	2947	1363
13500	3882	/	3176	2104	2104	462	2992	1384
14100	3939	/	3222	2135	2135	469	3036	1404
14700	3994	/	3267	2165	2165	476	3078	1424
15400	4056	/	3318	2199	2199	483	3126	1446
16100	4117	/	3368	2232	2232	490	3173	1468
16900	4184	/	3423	2268	2268	498	3225	1492
17800	4252	/	3479	2308	2308	506	3281	1518
18800	4330	/	3543	2350	2350	516	3341	1546
20000	4420	/	3617	2399	2399	526	3411	1578

AMARRA TIPO SPEK

AMARRA DE ESTOQUE

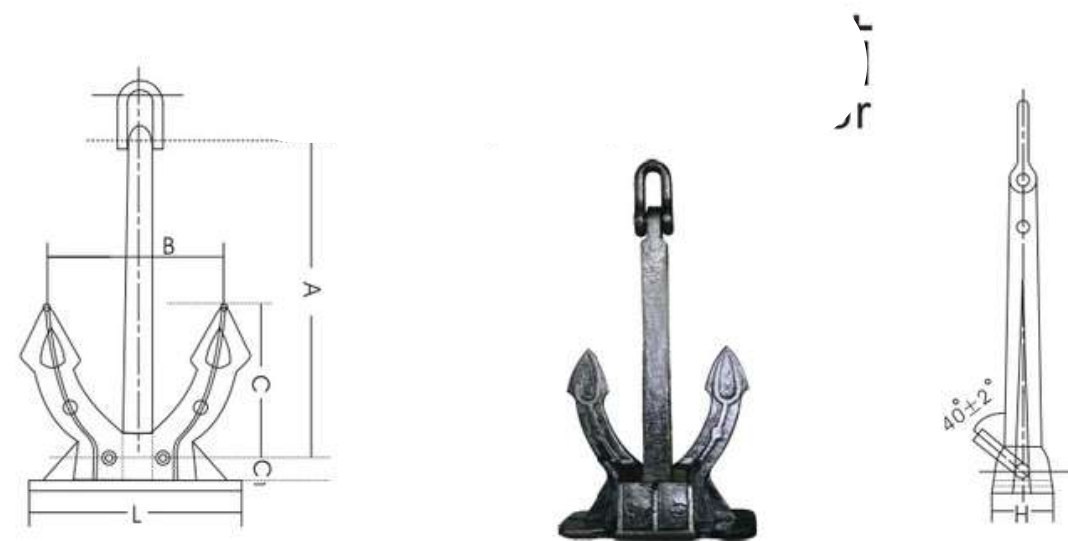

锚重 kg	A	B	C	C ₁	L	H
50	537	298	298	89	411	185
75	638	355	355	106	489	213
100	703	390	390	117	539	234
140	786	437	437	131	603	262
180	855	475	475	142	655	285
210	900	500	500	150	690	300
240	900	500	500	150	690	300
300	990	550	550	166	760	330
360	1080	600	600	180	828	360
420	1080	600	600	180	828	360
450	1150	600	600	180	828	360
480	1170	650	650	196	900	390
570	1170	650	650	196	900	390
610	1260	700	700	210	962	420
660	1260	700	700	210	962	420
750	1350	750	750	225	1032	450
780	1350	750	750	225	1032	450
900	1440	800	800	240	1100	480
950	1460	800	800	240	1100	480
1020	1530	850	850	252	1170	510
1140	1620	900	900	268	1240	540
1290	1710	900	900	268	1240	540
1440	1710	950	950	279	1300	570
1500	1710	950	950	279	1300	570
1590	1710	950	950	279	1300	570
1600	1710	950	950	279	1300	570
1740	1800	1000	1000	300	1378	600
1920	1890	1050	1050	312	1454	630
2100	1890	1050	1050	312	1454	630
2195	1890	1050	1050	312	1454	630
2280	1980	1050	1050	312	1454	630
2460	2010	1100	1100	324	1514	660
2640	2070	1150	1150	352	1584	690
2850	2070	1150	1150	352	1584	690
3060	2160	1200	1200	360	1650	720
3300	2160	1200	1200	360	1650	720
3540	2350	1200	1200	360	1650	720

锚重 kg	A	B	C	C ₁	L	H
3780	2430	1350	1350	393	1850	810
4050	2430	1350	1350	393	1850	810
4320	2520	1400	1400	413	1926	852
4590	2520	1400	1400	413	1926	852
4890	2520	1400	1400	413	1926	852
5250	2610	1450	1450	414	2000	870
5610	2610	1450	1450	414	2000	870
5800	2700	1500	1500	446	2060	900
6000	2700	1500	1500	446	2060	900
6450	2700	1500	1500	446	2060	900
6900	2890	1550	1550	456	2138	930
7350	2890	1550	1550	456	2138	930
7800	2920	1550	1550	456	2138	930
8000	3060	1550	1550	456	2138	930
8300	3060	1700	1700	510	2332	1020
8700	3060	1700	1700	510	2332	1020
9300	3060	1700	1700	510	2332	1020
9900	3160	1700	1700	510	2332	1020
10500	3190	1770	1770	531	2440	1060
11100	3290	1770	1770	531	2440	1060
11700	3390	1770	1770	531	2440	1060
12300	3440	1910	1910	573	2632	1146
12900	3440	1910	1910	573	2632	1146
13500	3440	1910	1910	573	2632	1146
14100	3440	1910	1910	573	2632	1146
14700	3690	2050	2050	615	2824	1230
15400	3690	2050	2050	615	2824	1230
16100	3690	2050	2050	615	2824	1230
16900	3820	2120	2120	636	2922	1270
17800	3920	2120	2120	636	2922	1270
18800	3970	2190	2190	657	3018	1314
20000	4070	2190	2190	657	3018	1314
21500	4168	2243	2243	673	3090	1346
23000	4265	2295	2295	689	3163	1377
24500	4355	2343	2343	703	3229	1406
26000	4440	2389	2389	717	3293	1434
27500	4526	2435	2435	731	3356	1461
29000	4621	2494	2494	748	3438	1494



锚重 kg	A	H	B	B ₁	L	L ₁
25	762	212	540	132	380	370
40	885	245	630	155	445	430
65	1038	288	740	180	520	500
90	1162	322	820	202	580	560
115	1258	350	890	220	630	610
140	1342	375	950	235	670	650
150	1380	385	980	240	690	670
180	1465	408	1040	255	730	710
205	1522	425	1080	265	760	740
215	1552	432	1100	270	770	750
240	1610	448	1140	280	800	780
265	1665	465	1190	290	820	800
290	1715	478	1220	300	850	830
315	1742	485	1240	305	870	840
330	1790	498	1270	312	890	860
355	1838	518	1300	320	920	890
395	1905	530	1350	332	950	920
445	1980	550	1400	345	990	960
485	2038	570	1440	355	1020	980
525	2085	580	1480	365	1040	1010
575	2152	600	1530	375	1070	1040
610	2200	610	1560	382	1100	1060
660	2255	630	1600	392	1130	1090
715	2312	650	1640	402	1160	1120
765	2360	660	1670	412	1180	1140
830	2428	680	1720	422	1210	1170
890	2495	700	1770	435	1250	1210
965	2560	710	1820	448	1280	1240
1045	2628	730	1860	458	1310	1270
1120	2685	750	1900	468	1340	1300
1195	2752	770	1950	480	1370	1330
1270	2808	780	1990	490	1400	1360
1350	2855	800	2030	498	1430	1380
1425	2912	810	2070	510	1460	1410
1500	2960	820	2110	520	1480	1440
1575	3008	840	2130	530	1510	1460
1655	3055	850	2170	530	1530	1480
1740	3112	870	2210	540	1560	1510
1830	3170	880	2250	550	1590	1540
1935	3228	900	2290	560	1620	1570
1985	3255	910	2310	570	1630	1580
2070	3302	920	2340	580	1660	1600
2160	3350	930	2380	590	1680	1630
2400	3470	960	2470	610	1740	1690

锚重 kg	A	H	B	B ₁	L	L ₁
2600	3560	990	2530	630	1790	1730
2800	3650	1010	2600	640	1830	1780
3000	3740	1030	2660	660	1870	1820
3200	3820	1060	2710	670	1920	1860
3400	3900	1080	2770	690	1950	1900
3600	3970	1100	2820	700	1990	1930
3800	4040	1120	2870	710	2030	1970
4000	4110	1140	2920	720	2060	2000
4300	4210	1170	2990	740	2110	2050
4650	4330	1200	3070	760	2170	2100
5000	4430	1230	3150	780	2220	2160
5300	4520	1250	3210	800	2270	2200
5650	4620	1280	3280	810	2310	2250
6000	4710	1310	3350	830	2360	2290
6300	4790	1330	3400	840	2400	2330
6550	4850	1350	3440	850	2430	2360
7000	4960	1380	3520	870	2490	2410
7500	5070	1410	3600	890	2540	2470
8000	5180	1440	3680	910	2560	2520
8500	5290	1470	3760	930	2650	2570
9000	5390	1500	3830	950	2700	2620
9500	5480	1520	3900	970	2750	2670
10000	5580	1560	3970	970	2800	2720
10500	5670	1580	4030	1000	2850	2760
11000	5670	1660	4100	1020	2890	2800
11500	5860	1620	4140	1030	2930	2840
12000	5930	1650	4020	1040	2980	2890
12500	6010	1670	4270	1060	3020	2930
13000	6090	1690	4330	1070	3060	2970
13500	6170	1710	4380	1090	3090	3000
14000	6250	1730	4440	1100	3130	3040
14500	6320	1750	4490	1110	3170	3070
15000	6390	1770	4540	1130	3210	3110
15500	6460	1790	4590	1140	3240	3140
16000	6530	1820	4640	1150	3270	3180
16500	6600	1830	4690	1160	3310	3210
17000	6660	1850	4730	1170	3340	3240
17500	6730	1870	4780	1190	3370	3270
18000	6790	1890	4830	1200	3410	3300
18500	6850	1900	4870	1210	3440	3330
19000	6920	1920	4910	1220	3470	3360
19500	6980	1940	4960	1230	3500	3390
20000	7040	1950	5000	1240	3530	3420

AC-14 H.H.P. AMARRA

EQUIPAMENTO DE AMARRAÇÃO DE AMARRAS

CHINA ANCHOR CHAIN www.zjzhuo.com



AC-14大抓力锚
AC-14 H.H.P. Anchor

锚重 kg	A	L	H	C	C ₁	B
30	491	440	136	299	85	236
45	590	529	164	359	107	283
75	677	605	188	411	122	324
94	718	643	199	437	130	344
112.5	745	666	207	452	135	357
135	821	737	228	500	143	394
180	904	811	251	550	157	434
225	974	874	270	593	169	468
270	1035	929	287	630	180	497
315	1090	978	302	663	189	524
360	1139	1022	316	694	198	547
427.5	1194	1071	331	727	206	574
495	1251	1122	347	762	216	602
585	1360	1221	378	828	236	654
675	1398	1254	387	851	242	672
765	1483	1304	404	885	264	698
855	1520	1363	423	925	267	729
967.5	1590	1425	440	968	275	764
1080	1631	1462	451	993	282	784
1192.5	1660	1490	465	1011	287	798
1305	1761	1580	488	1072	305	846
1440	1795	1610	497	1093	311	862
1575	1855	1665	514	1130	321	892
1710	1900	1705	526	1157	329	913
1845	1940	1741	538	1182	336	933
1980	1977	1774	548	1203	342	950
2137.5	2016	1809	559	1227	349	969
2295	2089	1874	579	1272	362	1004
2475	2150	1929	596	1309	373	1033
2655	2201	1975	610	1340	382	1057
2835	2253	2022	624	1372	390	1083
3037.5	2302	2066	638	1402	399	1107

锚重 kg	A	L	H	C	C ₁	B
3240	2352	2110	652	1432	407	1130
3442.5	2400	2154	665	1462	415	1154
3667.5	2451	2200	680	1493	424	1178
3937.5	2510	2252	696	1529	434	1207
4207.5	2566	2303	711	1563	444	1234
4500	2624	2355	727	1598	454	1261
4837.5	2688	2412	745	1637	465	1292
5175	2749	2467	762	1674	476	1321
5512.5	2808	2520	778	1710	486	1350
5850	2864	2570	794	1744	496	1376
6225	2923	2623	810	1780	506	1405
6525	2970	2665	823	1808	514	1428
6975	3042	2730	843	1853	527	1462
7425	3100	2782	859	1888	537	1490
7875	3162	2837	876	1925	547	1520
8325	3221	2890	893	1961	558	1548
8775	3278	2942	909	1996	567	1576
9225	3333	2991	924	2030	577	1602
9675	3386	3039	939	2062	586	1628
10125	3438	3085	953	2094	595	1653
10575	3488	3130	967	2124	604	1677
11025	3537	3174	981	2154	612	1700
11550	3592	3224	996	2188	622	1727
12075	3646	3272	1011	2220	631	1753
12675	3705	3325	1027	2256	641	1781
13350	3770	3383	1045	2296	653	1812
14100	3839	3445	1064	2338	665	1846
15000	3919	3517	1086	2387	678	1884
16125	4015	3603	1113	2445	695	1930
17250	4106	3685	1138	2501	711	1974
18375	4194	3763	1163	2554	726	2016
19500	4278	3839	1186	2605	740	2056



螺旋弃锚器
Helix Cable Releaser



A型锚链舱眼环
CB807-75
A Type Chain Cabin Eye Loop



B型锚链舱眼环
CB807-75
B Type Chain Cabin Eye Loop



导链滚轮
CB/T290-95
Wheel For Leading Chain



滚轮闸刀掣链器
CB/T3844-2000
Roller-type Cable Stopper



A型螺旋掣链器
CB/T178-96
A Type Helix Chain Stopper



闸刀掣链器
CB*286-84
Cast Steel Cable Stopper



A13锚浮标
A13 Anchor Buoy



锚唇
Anchor Mouth



掣链钩
CB*288-1964
Chain Stop Hook



A型掣锚索
CB*877-1984
Anchor Rope Stopper



锚链拆卸工具
CB*3276-1985
Anchor Chain Disengaging Tool